

PART NO. 24983 REV. 2
Printed in U.S.A.
Price .35

PARTS LIST

HOMELITE®

Super 2

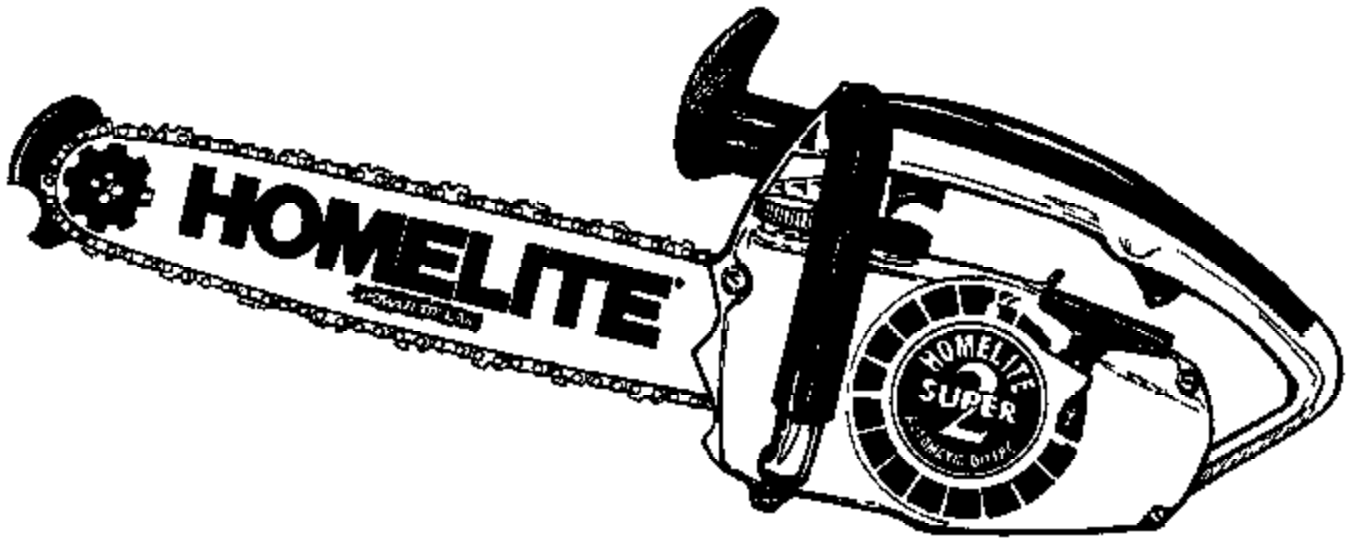

Automatic Oiling
CHAIN SAW

HOMELITE **TEXTRON**

Homelite Division of Textron Inc

SUPER 2
FIGURE 1

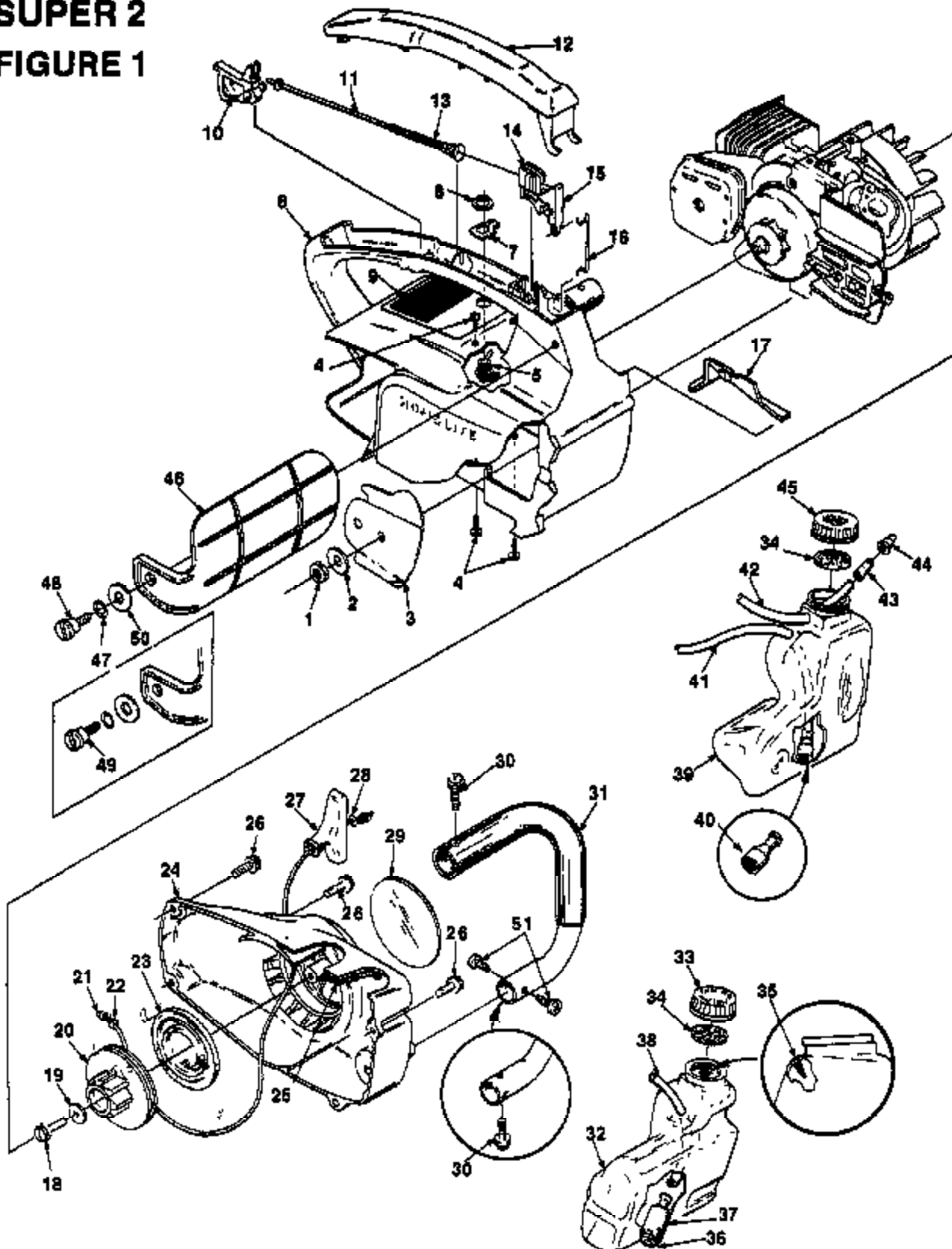

SUPER 2 FIGURE 1

NO.	DESCRIPTION	PART NO.	QTY.	NO.	DESCRIPTION	PART NO.	QTY.
1	NUT- Guide bar 1/4-28	81065-2	1	35	VALVE- Check (duck bill)	88451	1
2	WASHER- Flat	88308-A	1	36	FILTER- Fuel	A-88823	1
3	PLATE- Guide bar	88360-1	1		Includes:		
4	SCREW- Pan hd., 10-24 x 1/2	88820	4	37	ELEMENT- Felt	84083	1
5	SWITCH- Stop (grounding)	A-88888	1	38	LINE- Fuel 7 1/4"	70810-29	1
	Includes:			39	TANK- Oil	A-70898-A	1
6	NUT- Hex	72084-A1	1		Includes:		
7	PLATE- "On-Off"	70834	1	40	FILTER- Oil	A-88583	1
8	HOUSING- Engine	A-88882-B	1	41	LINE- Oil 6"	70809-24	1
	Includes:			42	LINE- Pressure	A-88888-B	1
8	PLATE- Starting instruction	70835	1		Includes:		
10	TRIGGER- Rear	88106-A	1	43	CONNECTOR- Oil	88558-B	1
11	ROD- Throttle	A-88186	1	44	VALVE- Check (duck bill)	88451	1
12	COVER- Handle	88140-A	1	45	CAP- Tank (oil) (black)		
13	SPRING- Throttle rod	88249	1		(Note 1)	A-70898-B	1
14	TRIGGER- Front	88106	1		Includes:		
15	LEVER- Throttle	88107	1		GASKET- Fuel filler cap		
16	ROD- Throttle (front)	88265-C	1		(Note 2) (See 34)	84838-A	1
17	COVER- Air filter	88263	1	46	GUARD- Hand (Note 3)	A-70796-B	1
18	SCREW- Hex washer hd.				Includes:		
	10-32 x 5/8 (Magnesium Housing)	80704	1	47	WASHER- Curved spring	88894	1
	SCREW- Thread forming			48	SCREW- Shoulder self tapping		
	13/84 x .750 (Plastic housing)	84565	1		(10-32) (Magnesium housing)	88713	1
19	WASHER- Flat (Magnesium housing)	88808-1	1	49	SCREW- Shoulder		
	WASHER- (Plastic housing)	84062	1		#10 thread forming (Plastic housing)	88714	1
20	PULLEY- Starter	88158-A	1	50	WASHER- Flat	88102	1
	PULLEY- Starter (alternate)	84562-A	1	51	SCREW- Pan hd.,		
21	ROPE- Starter #4, 34" long	A-88974-A	1		#8 x 1/2 (Plastic housing)	82348	2
	Includes:						
22	WASHER- Nylon	88862	1				
23	SPRING- Rewind	88217	1				
24	HOUSING- Rewind starter						
	(Plastic housing)	A-84241	1				
	HOUSING- Rewind starter						
	(Magnesium housing)	A-88540	1				
	Includes:						
25	FILTER- Fuel tank valve	88443	1				
26	SCREW- Hex 10-32 x 5/8	80704	4				
27	GRIP- Starter rope	70211	1				
28	WASHER- Flat	84025	1				
29	DECAL- Super 2	70240	1				
30	SCREW- Pan washer hd.						
	10-32 x 5/8 (Magnesium housing)	82239	2				
31	HANDLE BAR (Magnesium housing)	A-70218-A	1				
	HANDLE BAR (Plastic housing)	A-84971	1				
32	TANK- Fuel	A-70899-A	1				
	Includes:						
33	CAP- Tank fuel (red)						
	(Note 1)	A-70884-B	1				
	Includes:						
34	GASKET- Fuel filler cap						
	(Note 2)	84838-A	1				

NOTE 1: Tanks with internal threads require A-70448 Fuel cap and A-70448 oil cap. If internal threads in tank are worn order new external threaded tank.

NOTE 2: Use 70826 Gasket in A-70893 and A-70894 external thread caps. Use 88685 gasket for caps with internal threads.

NOTE 3: For units with steel handguard, requires 70728 Belleville washer and 70748 spacer, 80672 screw 10-32 x 5/8 (magnesium housing).

SUPER 2 FIGURE 2

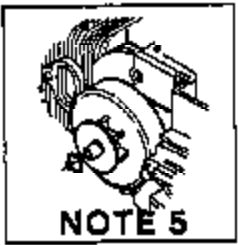
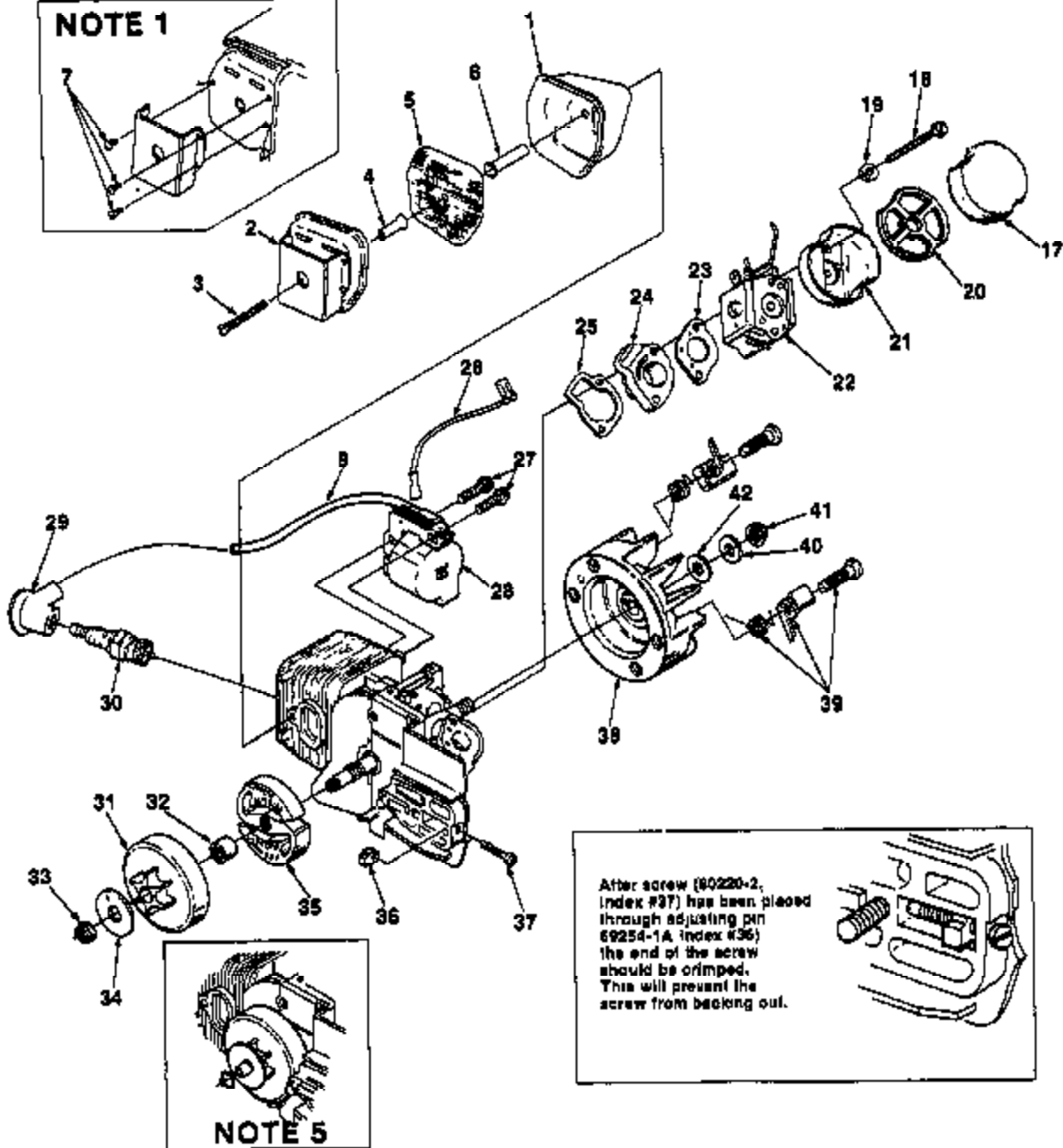
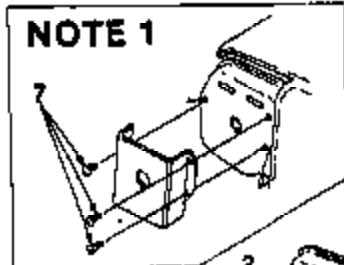
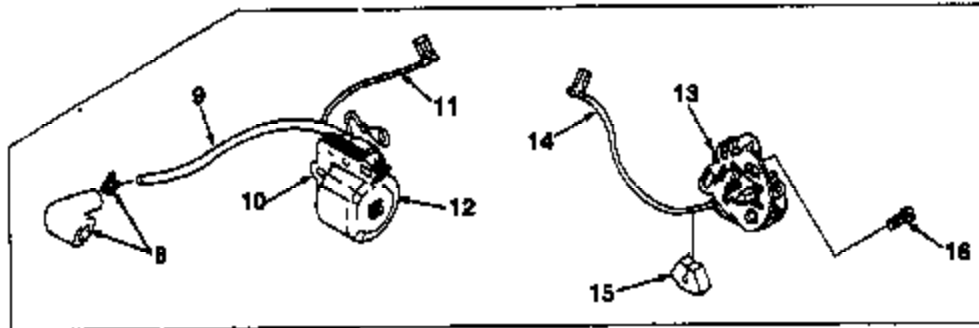

After screw (80220-2, Index #37) has been placed through adjusting pin 69254-1A (Index #36) the end of the screw should be crimped. This will prevent the screw from backing out.

SUPER 2 FIGURE 2

NO.	DESCRIPTION	PART NO.	QTY.	NO.	DESCRIPTION	PART NO.	QTY.
1	MUFFLER	A-94051-B	1	28	MODULE- Ignition (solid state)	94711	1
	Includes				Includes		
2	CAP- Muffler (w/shield) (Note 1)	A-95426	1	29	LEAD- High tension (see index #8)	99326	1
	SPARK ARRESTOR	A-94139	1		TERMINAL- Spark plug (solid state) (Note 3)		1
	Includes			30	SPARK PLUG- Champion DJ-7J	99616-B	1
3	SCREW	92320	1	31	SPROCKET & DRUM (Standard) (6 tooth 37 and 375 chain)	A-70221-C	1
4	SPACER- (Short)	93999	1		Includes		
5	SCREEN- Spark arrester	D-93991	1	32	BEARING- Needle	98512	1
6	SPACER- (Long)	93990	1	33	NUT- Locking 5/16 - 24 (Note 3)	91112	1
7	SCREW- 4 x .250 (Note 1)	92342	3	34	WASHER- thrust (clutch)	95299	1
8	TERMINAL- Spark plug	A-33055	1	35	CLUTCH- "S"	A-70351-A	1
9	LEAD- High tension (Note 2)	99326	1	36	PIN- Adjusting (see insert)	99254-1A	1
10	CORE- Coil (Point ignition)	99324	1	37	SCREW- Adjusting (fil hd 8-32 x 1) (See insert)	90220-2	1
11	LEAD- Stop switch (Point ignition)	A-96051	1	38	ROTOR & STARTER PAWL (Solid state (Phelon) ROTOR & STARTER PAWL (Point ignition) (Phelon)	A-94717-A A-99297-B	1 1
12	COIL- Ignition (Point ignition) RETAINER- Coil (not shown) (Point ignition)	99323 99325	1 1		Includes		
13	POINT SET- Breaker (point ignition)	A-99336	1	39	KIT- Starter pawl (Note 4)	A-70295-C	1
	Includes			40	WASHER- Lock	99002	1
14	LEAD- Electrical	70249	1	41	NUT- Rotor 5/16-24	91117	1
15	SEAL- Lead (point ignition)	99247	1	42	WASHER- Flat	94085-1	1
16	SCREW- Point set (point ignition)	99026	2				
17	FILTER- Air	99141	1				
18	SCREW- Hex hd 10-32 x 2 1/4	90481	2				
19	WASHER- Lock #10	93006-1	2				
20	RETAINER- Air filter	99457	1				
21	CUP- Air filter	99145	1				
22	CARBURETOR- HDC-85 (walbro)	A-94649-A	1				
	CARBURETOR- Zama (C2S-H5)	A-98481	1				
23	GASKET- Carburetor	95019	1				
24	MANIFOLD- Intake	A-99373-A	1				
25	GASKET- Intake manifold	99143	1				
26	LEAD- Ground (solid state)	A-94721	1				
27	SCREW- Hex w/washer (5-32 x 3/4)	92245	2				

NOTE 1: Units with separate shield require index #7 screws. All new muffler caps A-95426 includes a shield welded to cap.

NOTE 2: For Solid State Ignition cut wire to 9 1/2".

NOTE 3: Use A-33055 for service replacement.

NOTE 4: Replacement starter pawl kit, item #39 includes an oversized pin, paint, stamp or mark to identify oversized pin when installing. Oversize pin can be installed lightly only once. If oversize pin is removed, the entire rotor assembly must be replaced.

NOTE 5: Retaining ring 93972 required for crankshafts without threaded clutch end.

SUPER 2

FIGURE 3

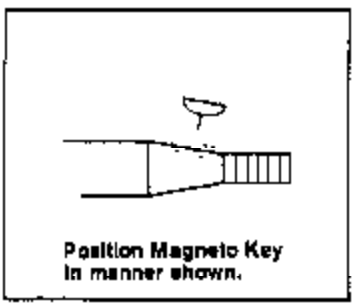
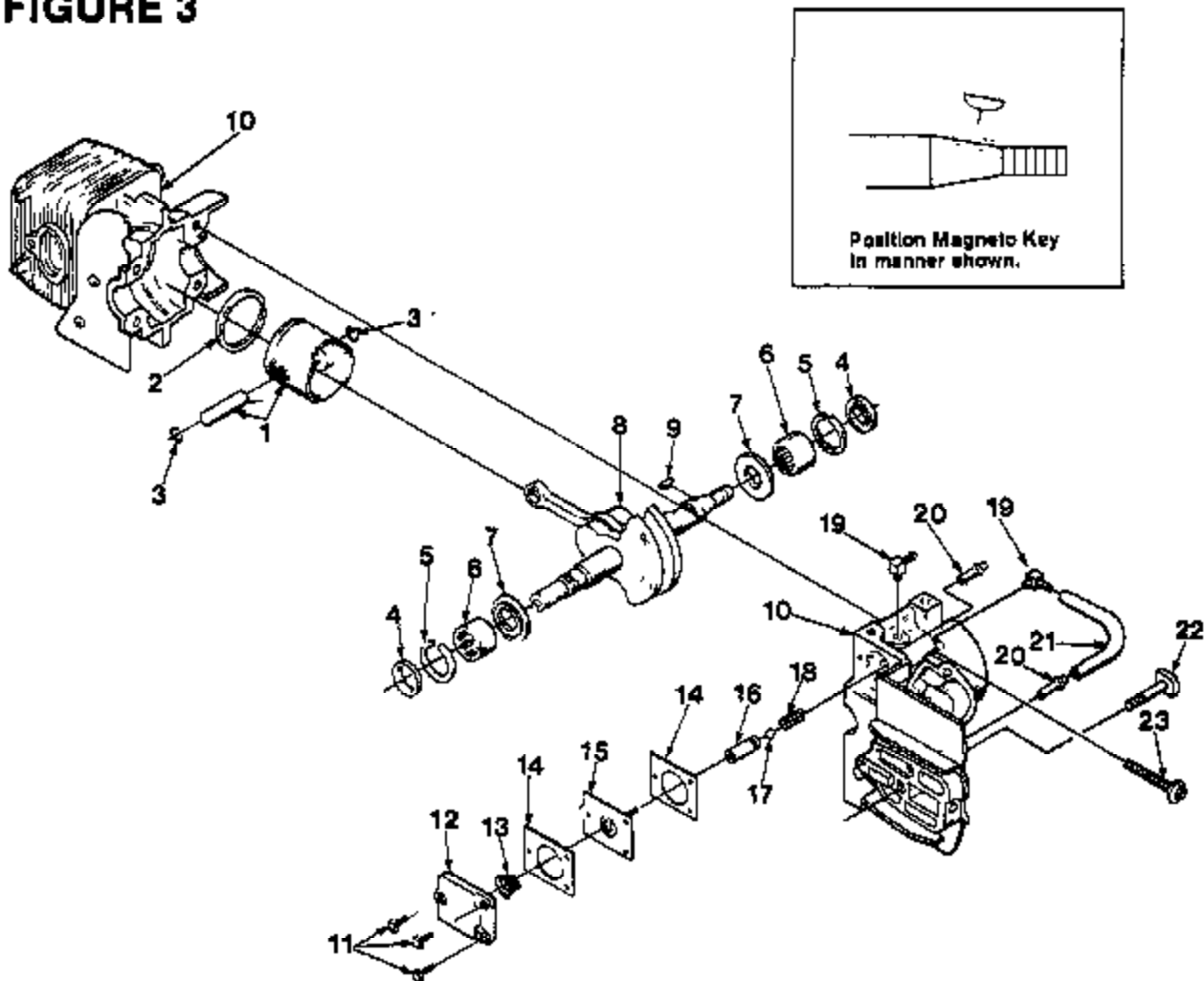

NO.	DESCRIPTION	PART NO.	QTY.	NO.	DESCRIPTION	PART NO.	QTY.
1	PISTON & PIN Includes	A-70224-A	1	12	COVER- Oil pump	88224-1C	1
2	PISTON RING	70206	1	13	SPRING- Oil pump	88447	1
3	RING- Piston pin retaining	86261	2	14	GASKET- Oil pump	88244-1	2
4	SEAL	94638	2	15	PLUNGER- Oil pump	A-12368-B	1
5	SPACER- Seal	89407	2	16	BODY- Oil pump	89343-1	1
6	BEARING- Needle	12530	2	17	BALL- Check valve	80051	1
	BEARING- Needle (opt.)	88513	2	18	SPRING- Check valve	88670	1
7	WASHER- Thrust	89093-B	2	19	FITTING- Oil line	70204	2
8	CRANKSHAFT (C/D Ignition)	A-88384	1	20	FITTING- Tube	88833	2
	CRANKSHAFT (point ignition)	A-88385	1	21	LINE- Oil	70161	1
	Includes			22	BOLT- Guide bar	89195	1
	NUT (Not shown)	81112	1	23	SCREW- Sem hex hd 8-32 x 1	88044	4
9	KEY- Magneto (see above)	88250	1				
10	CYLINDER & CRANKCASE (C/D)	A-95072	1				
	CYLINDER & CRANKCASE (point ignition)	A-70228	1				
11	SCREW- Pan hd. 8-32 x 3/8	80571	3				

SUPER 2

CARBURETOR A-94649-A HDC-65

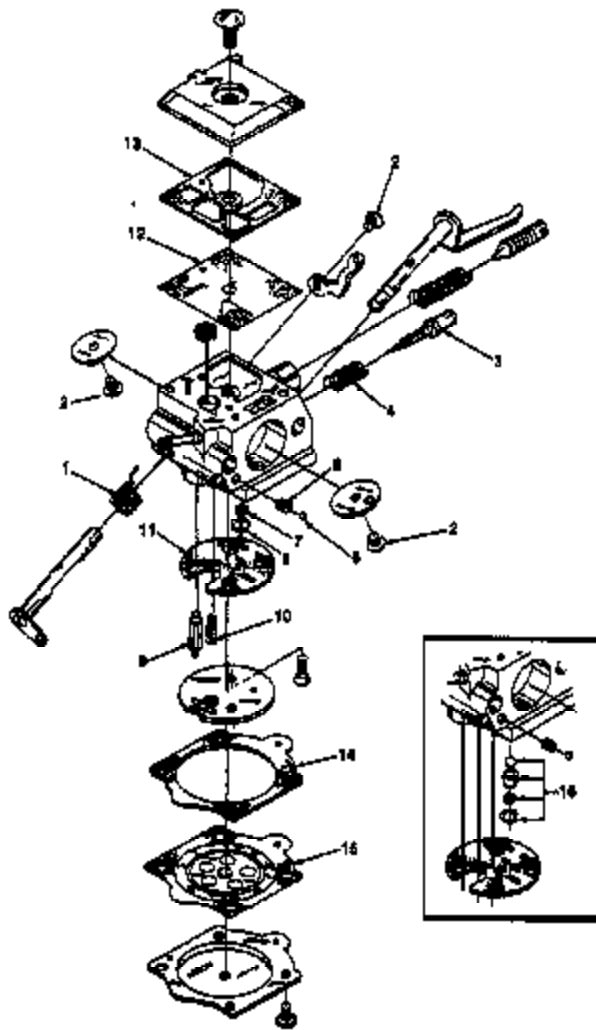

- 94056 Repair Kit (Includes 1-15)
- 94701 Gasket/Diaphragm Kit (Includes 11-15)
- 93910-A Check valve repair kit (16)
- 93188 Circuit Plate- High altitude .029 not shown
- 4229 Valve- Inlet needle (9)

CARBURETOR A-96481 (ZAMA) C2S-H5

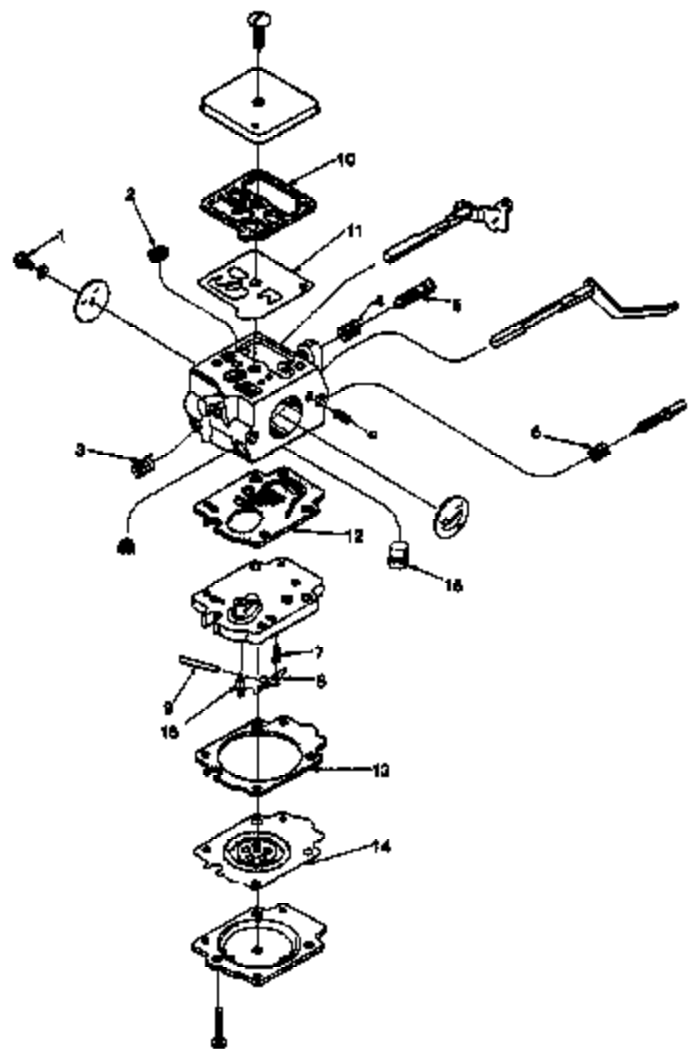

- 96484 Repair Kit (1-16)
- 96485 Diaphragm/Gasket Kit (10-14)

ACCESSORIES

GASKET- Oil pump body (repair)	69586
KIT- Repair (sprocket nose bar)	A-70239-B
KIT- Spark arrester (use with	
A-93686 muffler and A-89253-1 muffler)	A-69686-B
LINE- Fuel (10 ft. length)	70310-99
LINE- Oil (10 ft. length)	70309-99
SAFE-T-TIP (standard)	A-70775-A
Includes:	
SCREW (Special)	93695
GREASE- Multi-use	
(Sprocket bearing - PT guide bar)	17193
CARRYING CASE	94215-A
STARTING ROPE- 250 ft. reel #4	89848

TOOLS

SILASTIC (crankcase sealing)	24823
PLIERS- Tru-Arc (sprocket retaining ring)	17188
PULLER- Magneto rotor	A-24747-A
Includes:	
BOLT- 5/16-18 x 1 3/4 (1)	80288
NUT- Hex 5/16-18 (2)	81196
WRENCH- Spanner (clutch)	A-93791
Includes:	
PIN- Clutch spanner	23717-A
TOOL- Carburetor check valve installation	24972

HOMELITE DIVISION OF TEXTRON INC.
P.O. BOX 7047
14401 CAROWINDS BOULEVARD
CHARLOTTE, N.C. 28217

HOMELITE TEXTRON

Homelite Division of Textron Inc